

COZIR™

Ultra Low Power Carbon Dioxide Sensor

COZIR is an ultra low power (3.5mW^4), high performance CO_2 sensor, ideally suited for battery operation, portable instruments or solar powered applications. Based on GSS IR LED and Detector technology, and innovative optical designs, the *COZIR* offers the lowest power NDIR sensor available. *COZIR* is a third generation product from GSS – leaders in IR LED CO_2 sensing.

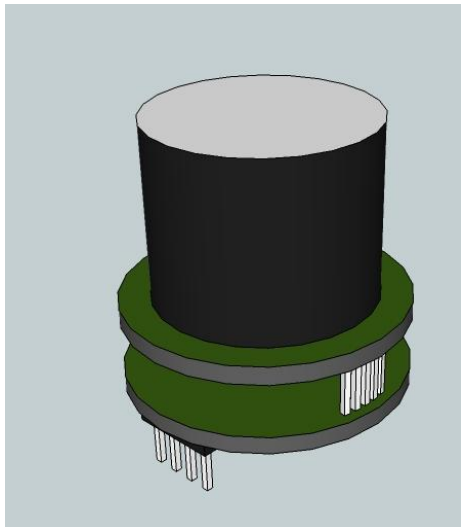

- Ultra-low Power 3.5mW
- Measurement ranges from 5% to 100%
- 3.3V supply.
- Peak current only 33mA.
- Optional Temperature and Humidity Output



Specifications

General Performance

Warm-up Time

- < 10s

Operating Conditions

- 0°C to 50°C (standard)
- -25°C to 55°C (extended range)
- 0 to 95% RH, non-condensing

Recommended Storage

- -30°C to +70°C

CO2 Measurement

Sensing Method

- Non-dispersive infrared (NDIR) absorption
- Patented Gold-plated optics
- Patented Solid-state source and detector

Sample Method

- Diffusion

Measurement Range

- 0-5%, 0-20%, 0-60%, 0-100%

Accuracy

- ± 70 ppm +/- 5% of reading¹

Non Linearity

- < 1% of FS

Pressure Dependence

- 0.13% of reading per mm Hg in normal atmospheric conditions.

Operating Pressure Range

- 950 mbar to 10 bar²

Response Time

- 4 secs to 2 mins (user Configurable)³
- Reading refreshed twice per second.³

Electrical/Mechanical

Power Input

- 3.2 to 5V. (3.3V recommended).
- Peak Current 33mA⁴.
- Average Current <1.5mA⁴.

Power Consumption

- 3.5 mW⁴

Dimensions and Wiring Connections

- 4x1 2mm header. 2x1 2mm header (NC)

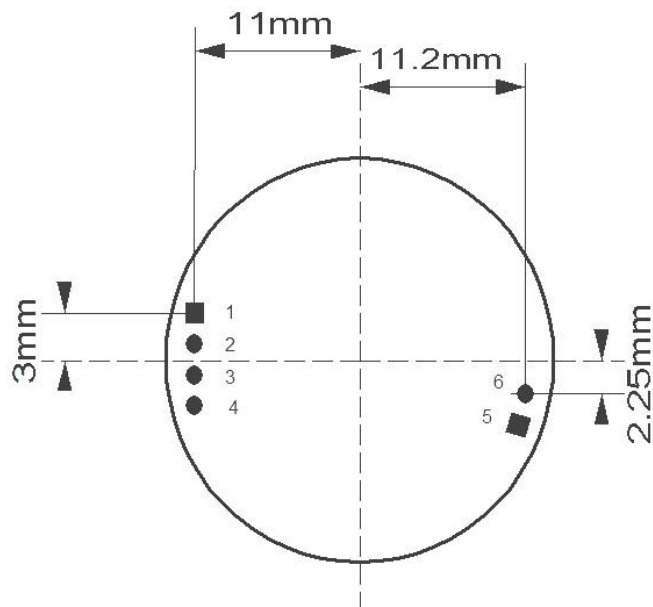

Function	Pin #	X	Y
0V	1	-11.0	3.0
+3.3V	2	-11.0	1.0
Sensor Rx	3	-11.0	-1.0
Sensor Tx	4	-11.0	-3.0
N2 Zero	5	10.64	-4.18
N/C	6	11.2	-2.25

This shows the position of the connectors looking from above the sensor. ie this is the correct pattern for a mating PCB.

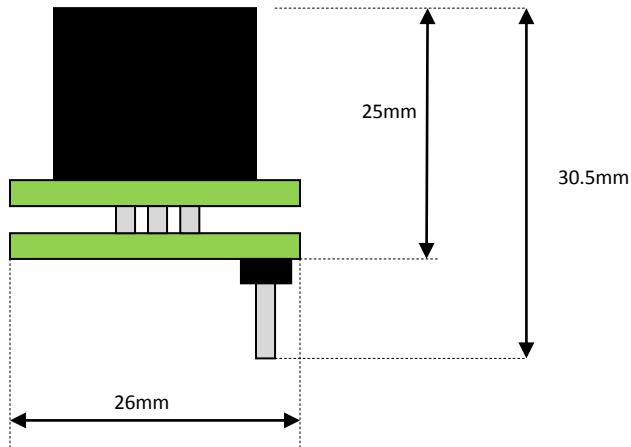

Pin 6 should not be connected. Pin 5 offers a nitrogen zero line, active low. It is recommended that this is left unconnected and that zeroing is performed using software commands sent over the UART.

Typical connections for digital interface are GND, 3.3V, Rx and Tx. Note that the Vh for the serial Tx line will be 3V regardless of the supply voltage.

Note 1: All measurements are at STP unless otherwise stated.

Note 2: External Pressure calibration required.

Note 3: User Configurable Filter Response.

Note 4: Power measurements for standard CO2 sensor with 2 readings per second.